



THE ALL-NEW MACK® MD SERIES

BUILT FOR GROWTH.



MACK MD6 LOW PROFILE

Dependability, durability and steadfast support—everything you’ve come to expect from Mack is now available in a medium-duty truck. We’re proud to introduce the Mack MD Series. These trucks are packed from the exterior to the driver environment with features to ensure a smooth, stress-free ride—backed by our unmatched local dealer support. The Mack MD6 Low Profile is designed for ease of street loading and vocations that require lower chassis height, such as towing and recovery.

Regular height model shown.

BORN READY.

MACK® MD6 LOW PROFILE

KEY FEATURES

Cab air suspension (standard)

Full-width aluminum grated steps, horizontally offset for visibility (standard)

50-gallon fuel tank (standard), 90-gallon (optional)

Frame rails rated at 120,000 psi yield strength (standard)

34-inch assembled frame width

Rear leaf spring suspension (standard), Mack AirRide (optional)

19.5-inch low profile tires on MD6 Low Profile version (standard)

Steel powder coat disc wheels (standard), aluminum wheels (optional)

Passenger door lower peep window (standard)

Flat back-of-cab and clear body platform for easy body upfit

Accommodates 10- to 26-foot typical van bodies

Clear space on driver and passenger side frame rails



Comfortable Interiors

The Mack MD6 Low Profile brings heavy-duty levels of driver comfort and functionality to medium-duty trucks, to keep drivers comfortable and safe all day. Tilt/telescoping steering column, air suspension driver seat and all controls within reach keep drivers in control.

All Day Uptime

Mack uses Geotab to integrate the MD6 Low Profile into our industry-leading Uptime Services. Mack's ASIST platform streamlines and shares all service communications among the customer, dealer and Mack's 24/7 Uptime Center.

Typical Dry Van Body Length	(ft.)	10	12/14	16	18	20	22	24	26
Wheelbase*	WB (in.)	150	166	186	206	221	236	251	270
Cab to Rear Axle	CA (in.)	87	103	123	143	158	173	188	207
After Frame	AF (in.)	50	55	60	65	70	80	90	100
Overall Length Chassis	OL (in.)	240	261	286	311	329	356	381	410
GVWR	(lb.)	25,995	25,995	25,995	25,995	25,995	25,995	25,995	25,995
Front Axle Capacity	(lb.)	10,000	10,000	10,000	10,000	10,000	10,000	10,000	10,000
Rear Axle Capacity	(lb.)	17,000	17,000	17,000	17,000	17,000	17,000	17,000	17,000

*Wheelbase selection should be based on specific weight distribution.

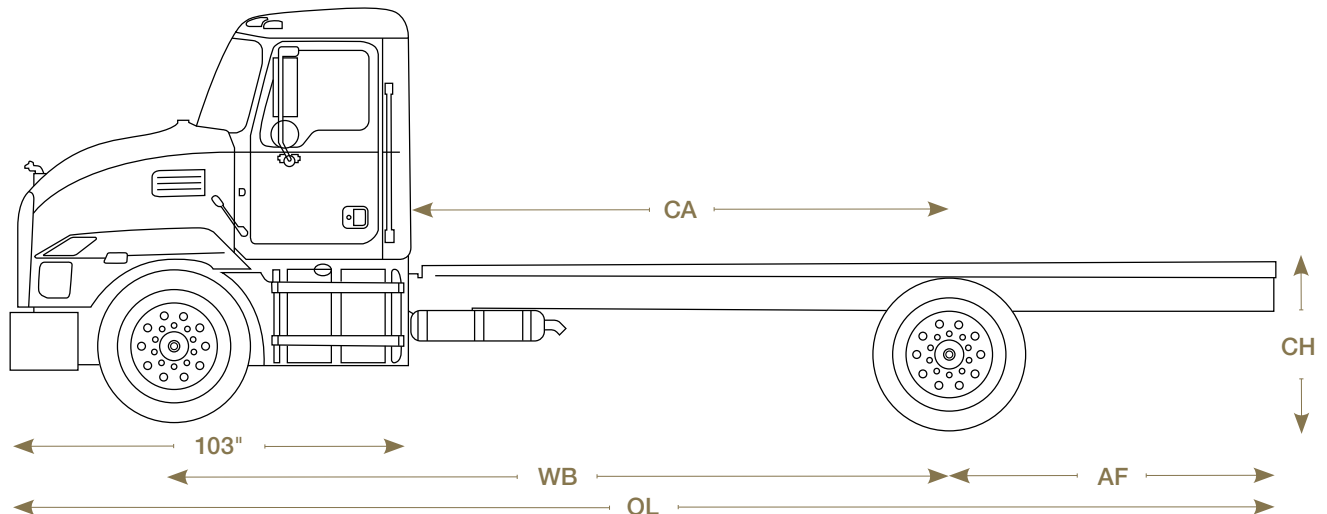

MACK® MD6 LOW PROFILE

ENGINE	Cummins B6.7 Inline 6-cylinder, Turbo/Intercooled Diesel
Horsepower/Torque	220 hp/600 lb. ft.
	240 hp/560 lb. ft.
	250 hp/660 lb. ft.
	260 hp/660 lb. ft.
	280 hp/660 lb. ft.
	300 hp/660 lb. ft.
Air Cleaner Type	11 in.
Alternator	Delco 12V, 145 amp
Batteries	Dual 760CCA (1520 total CCA)
Engine Brake	Cummins, w/dash switch
Starter	Melco12V

TRANSMISSION	STANDARD Allison 2500HS 6-speed, double OD rated to 660 lb. ft. torque, w/Fuel Sense 2.0 Plus	OPTIONAL Allison 2500RDS 6-speed, double OD rated to 660 lb. ft. torque, w/Fuel Sense 2.0 Plus

RATIOS

1st	3.51	3.51
2nd	1.90	1.90
3rd	1.44	1.44
4th	1.00	1.00
5th	0.74	0.74
6th	0.64	0.64
Rev.	-5.09	-5.09
RA Ratio	4.33*	4.63 4.88 4.33* 4.63 4.88
Est Engine RPM @ 65 mph	1953	2088 2201 1953 2088 2201

*4.33 R/A ratio not available with MS-17-13X rear axle.

FRONT AXLE

GAWR	10,000 lbs.
Axle Type	Meritor MFS-10, I-Beam
Suspension	Mack Taperleaf, 10,000 lbs.
Shock Absorbers	Telescopic type

REAR AXLE

	STANDARD	OPTIONAL	OPTIONAL	OPTIONAL
GAWR (lb.)	17,000	17,000	19,000	19,000
Axle Type – Meritor	MS-17-13x	MS-17-14x*	MS-19-13x*	MS-19-14x*
Suspension – Taperleaf (lb.)	19,000			
Suspension – Optional (lb.)	Mack AL 190 19,000**			

□ Shaded areas indicate optional equipment.

CAB	Steel cab w/premium trim level
Air Conditioning	Standard
Audio	AM/FM w/Bluetooth
Cab Lighting	Interior courtesy lights – 2
Cab Mirrors	Bright finish & lower convex mirror
Cab Suspension	Dual, airbag cab suspension
Cruise Control	Standard
Cup Holders	Two large cup holders in console
Passenger Door Window	Lower door window w/lens
Power Outlets	12 volt & USB
Power Steering	Standard
Power Windows & Locks	Standard
Pro Dash	Premium dash cluster
Seat Driver	High back, air suspension w/vinyl
Seat Passenger	High back, fixed base w/vinyl
Steering Column	Tilt & Telescopic
Steering Wheel	Flat-bottom steering wheel
Sunvisors	Driver & Passenger

BRAKE SYSTEM

	Bendix Antilock Braking System “S” Cam Air Brake System
Front Brakes	Meritor S Cam, 15.0" x 4" Q+
Rear Brakes	Meritor S Cam, 15.0" x 8 5/8" Q+
Parking Brake	Rear axle, spring brake

FUEL TANK

	Round 22", driver-side. 50 gallons
	Round 22", driver-side. 90 gallons

DEF TANK

	Passenger side. 25L
--	---------------------

WHEELS

	Accuride steel disc, 5-hole powder coated white wheels 7.50 x 19.5, offset 6.40" Accuride
	Accuride aluminum, 10-hole wheels 7.50 x 19.5, offset 6.25"

TIRES

	Bridgestone R238 radials All season, all position, 265/70R 19.5 (H, 14PR)
	Bridgestone M729F radials Traction, rear position, 265/70R 19.5 (H, 14PR)

*14x & DL, Rear axle option equipped with driver controlled differential lock.

**Rear air suspension available on 206-, 221-, 236-, 251- and 270-inch wheelbases only.

MACK® MD6 LOW PROFILE



Regular height model shown.

WARRANTY SUMMARY	MD Series Models MD6, MD7
Typical Vocations	Distribution, Short Haul or P&D
Axle Configuration	4 x 2
Basic Coverage	24 months/unlimited miles*
Batteries	12 months/unlimited miles
Chassis Towing	90 days or 5,000 miles (8 047 KM), whichever occurs first*
Air Conditioning	24 months/unlimited miles – air conditioning (sealed system only)
Engine/Emission	Warranty coverage provided by Cummins.
Transmission	Warranty coverage provided by Allison.
Driveline, Rear Axle, Front Steer Axle	24 months/unlimited miles*
Cab Structure & Internal Cab Corrosion	60 months/unlimited miles*
Frame Rail/Crossmembers	60 months/unlimited miles*
Noise Emission	Life of vehicle*

*See complete warranty certificate for details.

Shaded areas indicate optional equipment.

All illustrations, specifications and descriptions in this specification are based on the latest product information available at the time of this publication. The right is reserved to make changes in price, materials, equipment, design, specifications, diagrams and models, and to discontinue models of equipment at any time, without notice and without incurring any obligation whatsoever. For more information on additional options and accessories, contact Mack Trucks, Inc. (www.macktrucks.com).

UPTIME SUMMARY	MD Series Models MD6, MD7
Mack OneCall™	12 months
Mack ASIST	12 months
Geotab Basic	12 months
PURCHASE OPTIONS	
Mack OneCall	24-60 months, in 12 mo. increments
Mack Asist	24-60 months, in 12 mo. increments
Geotab Basic	24-60 months, in 12 mo. increments
Geotab Plus	12-60 months, in 12 mo. increments
OTHER OPTIONS	
Allison Upgrade	Fuel Sense 2.0 MAX
Battery Shut Off	Under cab, passenger side
Engine Block Heater	
Air Filter Indicator	Under hood, restriction indicator mounted to air cleaner
PTO Preparation Kit	Harness & switch kit
Cab Mirrors	Chrome finish & convex mirror heated & motorized
Seat Passenger	Two-person bench seat w/vinyl & under seat storage
Drivers Seat Trim	Modura cloth upgrade seat upholstery
Passenger Seat Trim	Modura cloth upgrade seat upholstery
Passenger Bench Trim	Modura cloth upgrade seat upholstery

